

ELATECH® iSync®

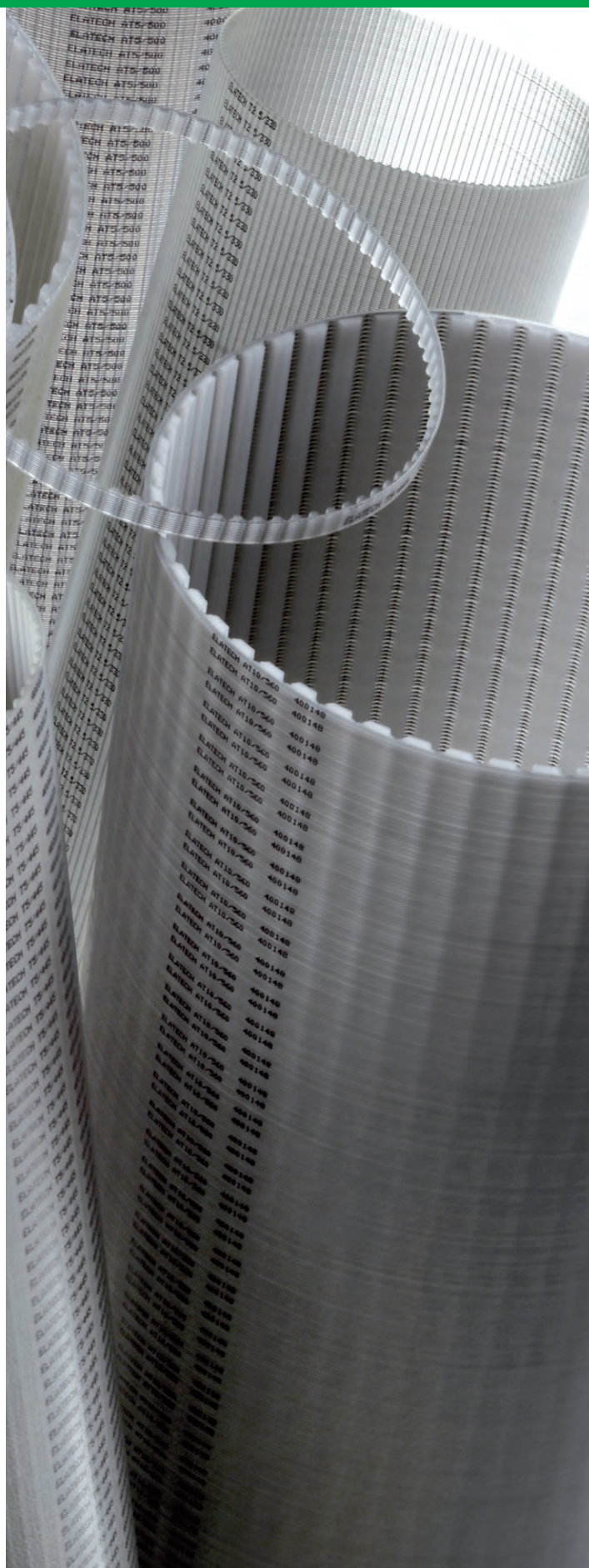

## iSync® AT 5

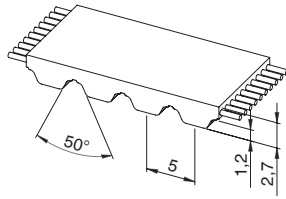
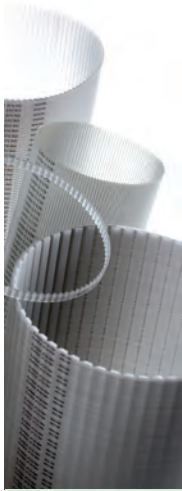

### Belt characteristics

- Truly endless polyurethane timing belt with steel tension cords
- Tooth profile according to ISO 17396
- Metric pitch 5 mm
- Tooth profile and dimension are optimised to guarantee uniform load distribution and minimum deformation under load
- High resistance and low stretch steel cords to guarantee high stability and low elongation
- Reduced polygonal effect with reduced drive vibration and noise
- Rpm up to 10.000 [1/min]

- Width tolerance: ±0,5 [mm]
- Thickness tolerance: ±0,15 [mm]

### Technical Data

Belt width [mm]	6	10	16	25	32	50	75	100
Allowable tensile load [N]	430	790	1350	2200	2950	4700	7100	9500
Weight [g/m]	21	34	54	86	110	175	260	350

Other widths are available on request.

### Tooth shear strength

rpm [min <sup>-1</sup> ]	M <sub>spez</sub> [Ncm/cm]	P <sub>spez</sub> [W/cm]	rpm [min <sup>-1</sup> ]	M <sub>spez</sub> [Ncm/cm]	P <sub>spez</sub> [W/cm]	rpm [min <sup>-1</sup> ]	M <sub>spez</sub> [Ncm/cm]	P <sub>spez</sub> [W/cm]
0	3,813	0,000	1200	2,668	3,352	3400	1,993	7,096
20	3,758	0,079	1300	2,620	3,566	3600	1,954	7,368
40	3,708	0,155	1400	2,574	3,773	3800	1,917	7,627
60	3,663	0,230	1440	2,557	3,855	4000	1,881	7,879
80	3,623	0,304	1500	2,531	3,975	4500	1,799	8,479
100	3,586	0,376	1600	2,491	4,173	5000	1,725	9,032
200	3,448	0,722	1700	2,452	4,365	5500	1,658	9,549
300	3,343	1,050	1800	2,416	4,554	6000	1,596	10,029
400	3,235	1,355	1900	2,381	4,737	6500	1,539	10,473
500	3,137	1,642	2000	2,348	4,918	7000	1,485	10,887
600	3,050	1,916	2200	2,285	5,265	7500	1,436	11,278
700	2,972	2,178	2400	2,229	5,601	8000	1,389	11,635
800	2,900	2,430	2600	2,175	5,923	8500	1,346	11,980
900	2,834	2,671	2800	2,125	6,231	9000	1,304	12,289
1000	2,775	2,905	3000	2,106	6,352	9500	1,264	12,576
1100	2,719	3,132	3200	2,079	6,531	10000	1,228	12,854

The total power "P" and the total torque "M" transmitted by the belt, are calculated with the following formulas:

$$P \text{ [kW]} = P_{\text{spez}} \cdot Z_e \cdot Z_k \cdot b / 1000$$

$$M \text{ [Nm]} = M_{\text{spez}} \cdot Z_e \cdot Z_k \cdot b / 100$$

$$Z_e = \frac{Z_k}{180} \cdot \arccos \left[ \frac{t \cdot (z_g - z_k)}{2 \cdot \pi \cdot A} \right]$$

- P = power in kW
- M = torque in Nm
- P<sub>spez</sub> = specific power
- M<sub>spez</sub> = specific torque
- Z<sub>e</sub> = number of teeth in mesh of the small pulley
- Z<sub>emax</sub> = 12
- Z<sub>k</sub> = number of teeth of the small pulley
- b = belt width in cm
- A = centre distance [mm]
- t = pitch

### Flexibility

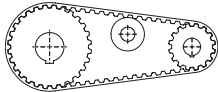
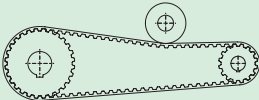
Minimum pulley number of teeth and minimum idler diameter			
Drive without reverse bending		Timing pulley Z <sub>min</sub>	15
		Flat idler running on belt teeth d <sub>min</sub>	25 mm
Drive with reverse bending		Timing pulley Z <sub>min</sub>	20
		Flat idler running on belt back d <sub>min</sub>	60 mm



# iSync® AT 10

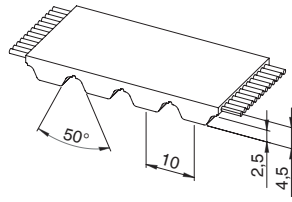
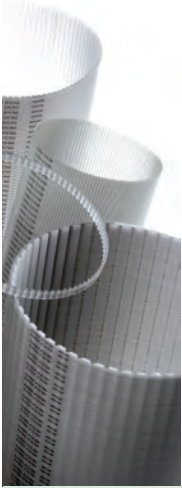

### Belt characteristics

- Truly endless polyurethane timing belt with steel tension cords
- Tooth profile according to ISO 17396
- Metric pitch 10 mm
- Tooth profile and dimension are optimised to guarantee uniform load distribution and minimum deformation under load
- High resistance and low stretch steel cords to guarantee high stability and low elongation
- Reduced polygonal effect with reduced drive vibration and noise
- Rpm up to 10.000 [1/min]

- Width tolerance: ±0,5 [mm]
- Thickness tolerance: ±0,2 [mm]

### Technical Data

Belt width [mm]	16	25	32	50	75	100	150
Allowable tensile load [N]	3150	5450	7100	11000	17200	23000	34600
Weight [g/m]	101	158	200	316	475	630	950

Other widths are available on request.

### Tooth shear strength

rpm [min <sup>-1</sup> ]	M <sub>spez</sub> [Ncm/cm]	P <sub>spez</sub> [W/cm]	rpm [min <sup>-1</sup> ]	M <sub>spez</sub> [Ncm/cm]	P <sub>spez</sub> [W/cm]	rpm [min <sup>-1</sup> ]	M <sub>spez</sub> [Ncm/cm]	P <sub>spez</sub> [W/cm]
0	15,903	0,000	1200	10,174	12,785	3400	7,019	24,989
20	15,670	0,328	1300	9,945	13,538	3600	6,838	25,778
40	15,452	0,647	1400	9,731	14,266	3800	6,664	26,516
60	15,246	0,958	1440	9,649	14,550	4000	6,500	27,225
80	15,053	1,261	1500	9,529	14,968	4500	6,120	28,837
100	14,870	1,557	1600	9,340	15,649	5000	5,777	30,248
200	14,103	2,954	1700	9,160	16,305	5500	5,464	31,470
300	13,483	4,236	1800	8,990	16,944	6000	5,179	32,536
400	12,927	5,414	1900	8,828	17,563	6500	4,916	33,460
500	12,439	6,513	2000	8,672	18,162	7000	4,670	34,232
600	12,008	7,545	2200	8,380	19,305	7500	4,441	34,878
700	11,626	8,522	2400	8,113	20,390	8000	4,227	35,409
800	11,282	9,451	2600	7,866	21,414	8500	4,023	35,808
900	10,969	10,337	2800	7,632	22,378	9000	3,832	36,113
1000	10,683	11,186	3000	7,544	22,751	9500	3,651	36,322
1100	10,418	12,000	3200	7,416	23,296	10000	3,479	36,429

The total power "P" and the total torque "M" transmitted by the belt, are calculated with the following formulas:

$$P \text{ [kW]} = P_{\text{spez}} \cdot Z_e \cdot Z_k \cdot b / 1000$$

$$M \text{ [Nm]} = M_{\text{spez}} \cdot Z_e \cdot Z_k \cdot b / 100$$

$$Z_e = \frac{Z_k}{180} \cdot \arccos \left[ \frac{t \cdot (z_g - z_k)}{2 \cdot \pi \cdot A} \right]$$

- P = power in kW
- M = torque in Nm
- P<sub>spez</sub> = specific power
- M<sub>spez</sub> = specific torque
- Z<sub>e</sub> = number of teeth in mesh of the small pulley
- Z<sub>emax</sub> = 12
- Z<sub>k</sub> = number of teeth of the small pulley
- b = belt width in cm
- A = centre distance [mm]
- t = pitch

### Flexibility

Minimum pulley number of teeth and minimum idler diameter			
Drive without reverse bending		Timing pulley Z <sub>min</sub>	15
		Flat idler running on belt teeth d <sub>min</sub>	50 mm
Drive with reverse bending		Timing pulley Z <sub>min</sub>	25
		Flat idler running on belt back d <sub>min</sub>	120 mm