

METALDRIVE® Disc Couplings

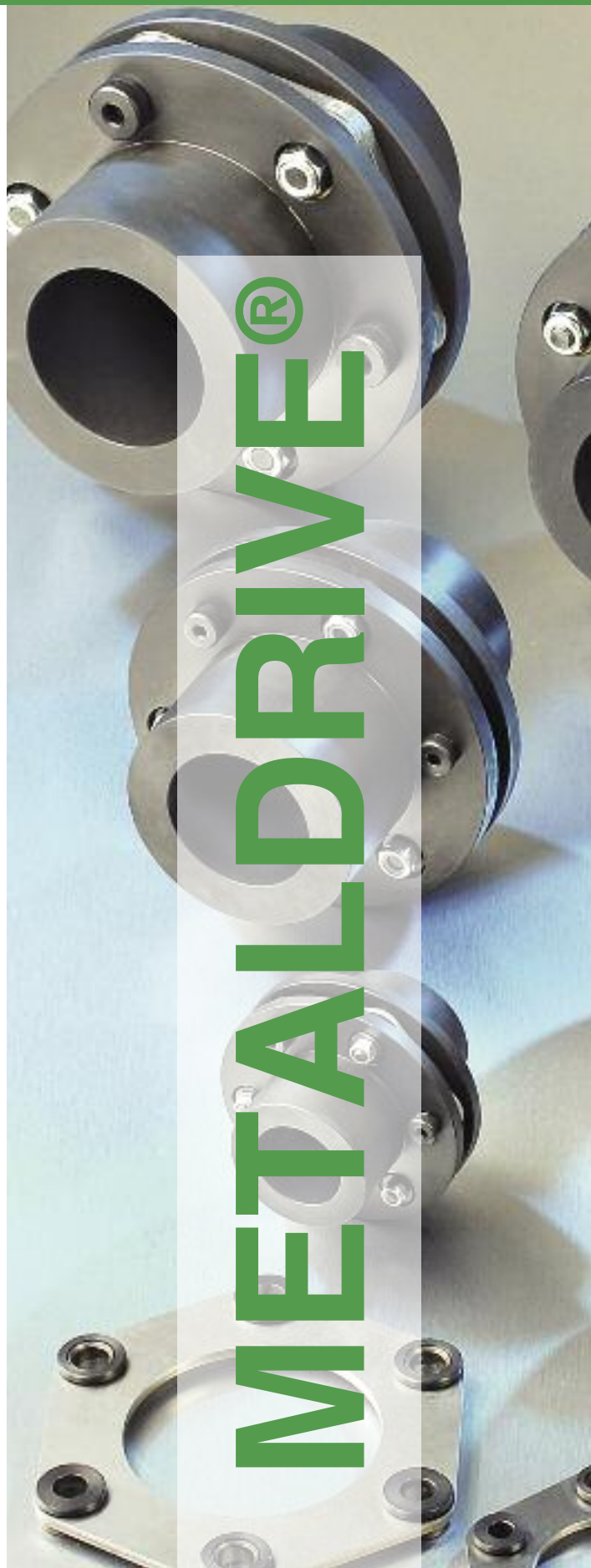

METALDRIVE®

Contents

METALDRIVE® Disc Couplings	Page
Features	85
METALDRIVE® disc coupling executions	86
Technical characteristics	87
• GMD type S	88
• GMD type E-I	89
• GMD type DC	90
• GMD type DCA (API671 - API610)	91
• GMD type SA1 - SA2	92
Hub-shaft connections	93
Selection procedure	94
METALDRIVE® couplings weight and inertia	95
Disc pack executions	95
Installation and maintenance	96



METALDRIVE® disc couplings

METALDRIVE® couplings are fully made of steel and are used in all applications where high reliability, precision, and no maintenance are required.

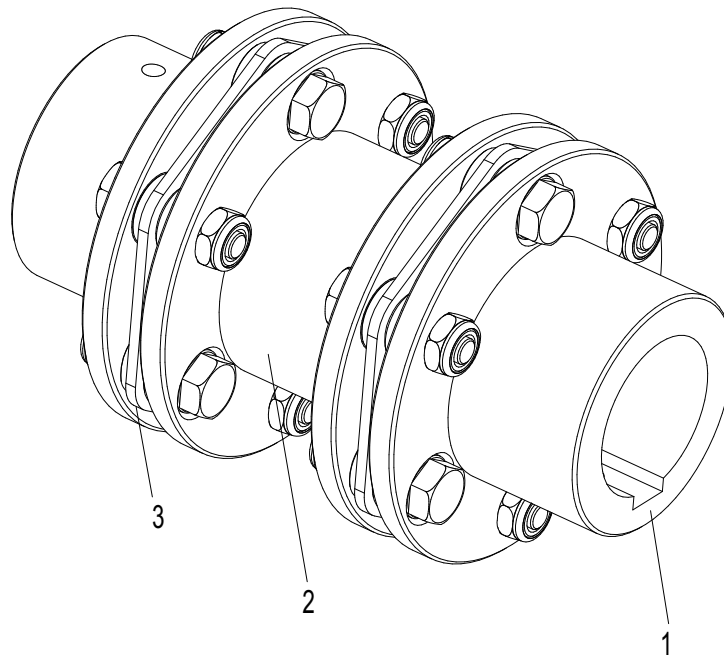

Features

- All steel
- Superior disc pack profile and assembly optimized for higher torque and misalignment and lower restoring forces
- Maintenance, lubrication and wear free
- Backlash free and torsionally rigid
- Wide range of temperature allowed: -40 °C to 250 °C
- Easy installation
- Bi-directional
- Modular design
- Allow axial, angular, and radial misalignment (only with double disc pack)
- Available in stainless steel for corrosive environment application
- **Approved according to ATEX Directive 2014/34/EU.**



Esecuzioni dei giunti METALDRIVE®

GMD type S

Standard version with single disc pack. The coupling allows axial and angular misalignment. No radial misalignment is allowed.

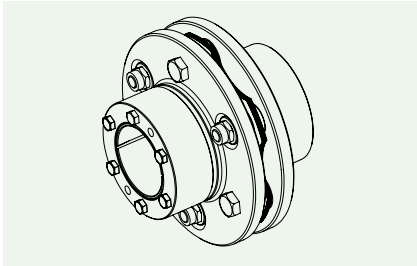
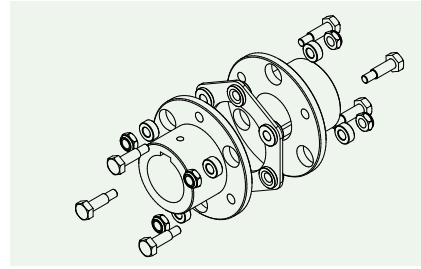

GMD type E-I

Standard version with shrink disc.

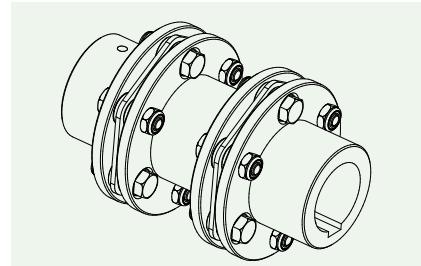

GMD type DC

Standard version with double disc pack and standard length spacer. Allows axial angular and radial misalignment. It is possible to mount the hubs reverse (hub R) to obtain a compact drive. It is not possible the radially mounting of the spacer.

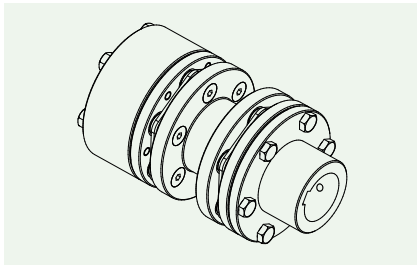

GMD type DCA

Double disc pack execution and anti-fail device. Standard spacer lengths for pump applications. This execution is available in conformity to API 610 e API 671.

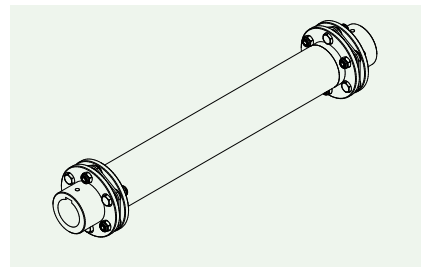

GMD type SA1

Tubular shaft version. Shaft is available in various lengths and can be delivered in welded aluminum or steel.
Available with carbon shaft.

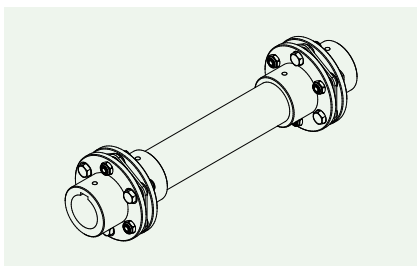

GMD type SA2

Shaft version with solid shaft construction. Variable shaft lengths are available.

Technical Features

Size	Torque (Nm)			Misalignment				Max rotation speed without balancing [min ⁻¹]	Torsional stiffness per disc pack [Nm/rad · 10 ⁶]
	Nominal Tkn[Nm]	Max Tkmax [Nm]	Reverse Tkw [Nm]	Axial ΔKa [mm] per disc pack	Angular α [°] per disc pack	Radial Δkr DCL execution	Radial ΔKr [mm] with spacer		
32-6	100	200	30	0,8	0,75	0,32	$(P_1 \cdot P) \cdot \tan \alpha$	11500	0,12
38-6	150	300	50	0,9	0,75	0,42		10000	0,16
45-6	300	600	100	1,2	0,75	0,53		8200	0,42
52-6	700	1400	230	1,4	0,75	0,74		6700	0,98
65-6	1100	2200	370	1,6	0,75	0,84		5700	1,85
80-6	1700	3400	570	1,8	0,75	0,92		5000	2,24
90-6	2600	5200	870	1,8	0,75	0,96		4500	3,6
95-6	4000	8000	1330	2	0,75	1,45		4100	9
110-6	7000	14000	2330	2,2	0,75	1,45		3600	11,90
120-6	9000	18000	3000	2,4	0,75	1,6		3100	14,20
138-6	12000	24000	4000	2,6	0,75	1,6		2900	15,60
155-8	25000	50000	8330	2,9	0,5	2,95		2600	37,80
175-8	35000	70000	11670	3,1	0,5	3,15		2400	51,60
190-8	50000	100000	16670	3,4	0,5	3,4		2200	64,40
205-8	65000	130000	21670	3,8	0,5	3,85		2000	69,50

The torsional rigidity of a coupling with spacer is calculated as follows:

$$C_T = \frac{1}{\frac{2}{C_{TL}} + \frac{P_1 - 2P}{C_{TS}}}$$

With C_{TS} = spacer torsional rigidity

Operating speed must be equal or less than permissible speed.

METALDRIVE® coupling balancing

All the components of the METALDRIVE® couplings are completely machined (spacer excluded) and balanced in class DIN ISO 1940-1 Q 6,3. Therefore, the balancing is unnecessary in most applications.

In cases where a higher degree of balancing is required, it is important to consider:

- Rotation speed and coupling diameter
- Rotation speed and intermediate shaft length
- Rotation speed and special balancing need of the machine

According to the requirement, METALDRIVE® coupling can be statically or dynamically balanced according to DIN ISO 1940-1. As a standard, the balancing is made on the single coupling component. On specific request the assembled coupling can be balanced. Also as a standard the balancing is made before the key seat machining. The balancing after the key seat machining is made on specific request. Permissible speed could be limited by the weight and critical speed of spacers. Please consult our technical department.

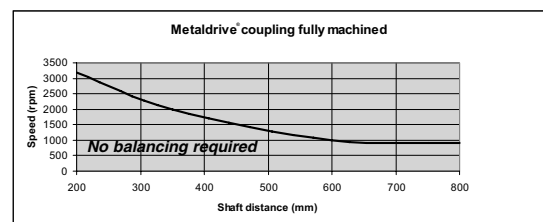
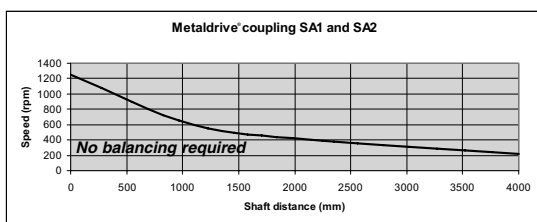

Working temperature

-40 °C + 250 °C

Misalignment

METALDRIVE® couplings with double disc packs allow axial, angular, and radial misalignment.

METALDRIVE® couplings with a single disc pack allows only axial and angular misalignment.

Please note that application must not have the maximum value of axial and angular misalignment at the same time.

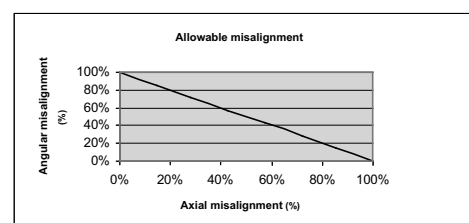

METALDRIVE® GMD type “S”

Standard version with single disc pack. The coupling allows axial and angular misalignment. No radial misalignment is allowed.

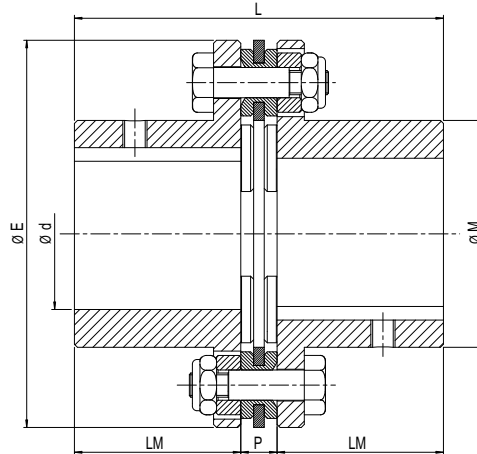

Size	Dimensions [mm]							Screws		
	Prebored	d max	E	M	LM	P	L	No.	Type	Tightening torque Ms [Nm]
32	-	32	80	45	40	8	88	6	M5	8,5
38	-	38	92	53	45	8	98	6	M5	8,5
45	-	45	112	64	45	10	100	6	M6	14
52	-	52	136	75	55	12	122	6	M8	35
65	-	65	162	92	65	13	143	6	M10	69
80	35	80	182	112	80	14	174	6	M10	69
90	50	90	206	130	80	15	175	6	M12	120
95	55	95	226	135	90	22	202	6	M14	190
110	65	110	252	155	100	25	225	6	M16	295
120	75	120	296	170	110	32	252	6	M24	1000
138	80	138	318	195	140	32	312	6	M24	1000
155	80	155	352	218	150	32	332	8	M24	1000
175	80	175	386	252	175	37	387	8	M27	1500
190	80	190	426	272	190	37	417	8	M30	2000
205	80	205	456	292	205	42	452	8	M33	2450

Order form

Hub/Disc pack **GMD 032 MF16**

GMD: METALDRIVE® hub

Size

M: solid standard hub
 PL: Disc pack
 F...: bore diameter

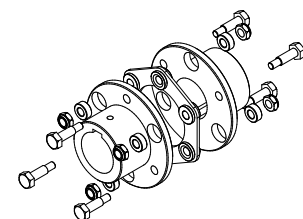

METALDRIVE® GMD type “E-I”

Standard version with shrink disc.

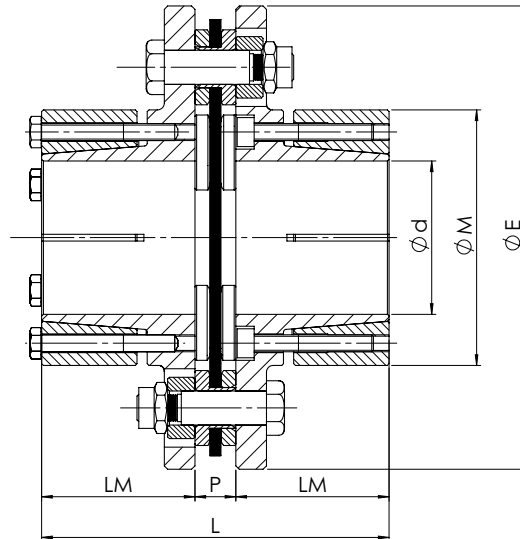

Size	Dimensions [mm]							Screws			Disc pack screws		
	F min	F max	E	M	LM	P	L	No.	Type	Tightening torque Ms [Nm]	No.	Type	Tightening torque Ms [Nm]
38	14	26	92	55	40	8	88	4	M5	6	6	M5	8,5
45	14	38	112	65	40	10	90	8	M5	6	6	M6	14
52	25	45	136	75	45	12	102	6	M5	8	6	M8	35
65	30	48	162	85	50	13	113	6	M6	8	6	M10	69
80	35	60	182	105	55	14	124	6	M8	35	6	M10	69
90	35	65	206	120	60	15	135	6	M8	35	6	M12	120

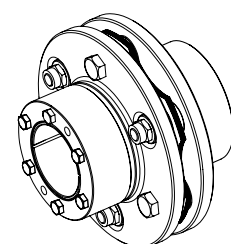

METALDRIVE® GMD type “DC”

Standard version with double disc pack and spacer.

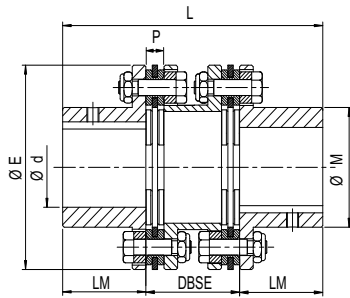

DC

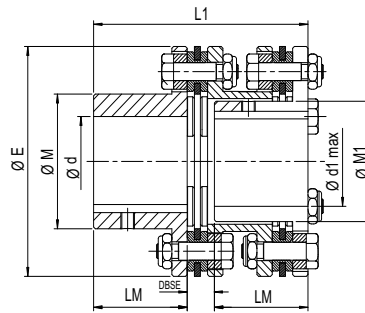

DC 1MR

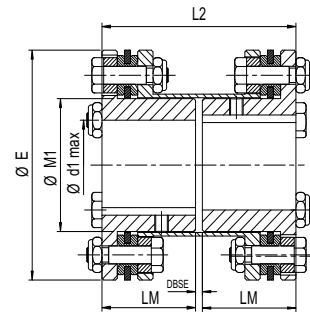

DC 2MR

Size	Dimensions [mm]												
	d max	E	M	LM	P	DC		M1	d1 max	DC 1MR		DC 2MR	
						DBSE min.	L			DBSE min.	L1	DBSE min.	L2
32	32	80	45	40	8	45	DBSE + 80	35	25	12	DBSE + 80	3	DBSE + 80
38	38	92	53	45	8	50	DBSE + 90	43	30	12	DBSE + 90	3	DBSE + 90
45	45	112	64	45	10	52	DBSE + 90	54	38	14	DBSE + 90	3	DBSE + 90
52	52	136	75	55	12	62	DBSE + 110	63	45	16	DBSE + 110	3	DBSE + 110
65	65	162	92	65	13	73	DBSE + 130	73	52	17	DBSE + 130	4	DBSE + 130
80	80	182	112	80	14	86	DBSE + 160	85	60	18	DBSE + 160	4	DBSE + 160
90	90	206	130	80	15	87	DBSE + 160	101	72	19	DBSE + 160	6	DBSE + 160
95	95	226	135	90	22	103	DBSE + 180	102	75	26	DBSE + 180	6	DBSE + 180
110	110	252	155	100	25	114	DBSE + 200	126	90	29	DBSE + 200	6	DBSE + 200
120	120	296	170	110	32	135	DBSE + 220	132	95	41	DBSE + 220	6	DBSE + 220
138	138	318	195	140	32	157	DBSE + 280	154	110	37	DBSE + 280	8	DBSE + 280
155	155	352	218	150	32	163	DBSE + 300	180	130	35	DBSE + 300	8	DBSE + 300
175	175	386	252	175	37	191	DBSE + 350	210	150	43	DBSE + 350	10	DBSE + 350
190	190	426	272	190	37	203	DBSE + 380	230	170	43	DBSE + 380	10	DBSE + 380
205	205	456	292	205	42	220	DBSE + 410	235	175	48	DBSE + 410	12	DBSE + 410

METALDRIVE® GMD type “DCA” (API 671-API 610)

Standard version with double disc pack and standard length spacer. Double disc pack execution with anti-fail device. Various spacer lengths available for pump applications. Conforms to API 610 - API 671.

API 671

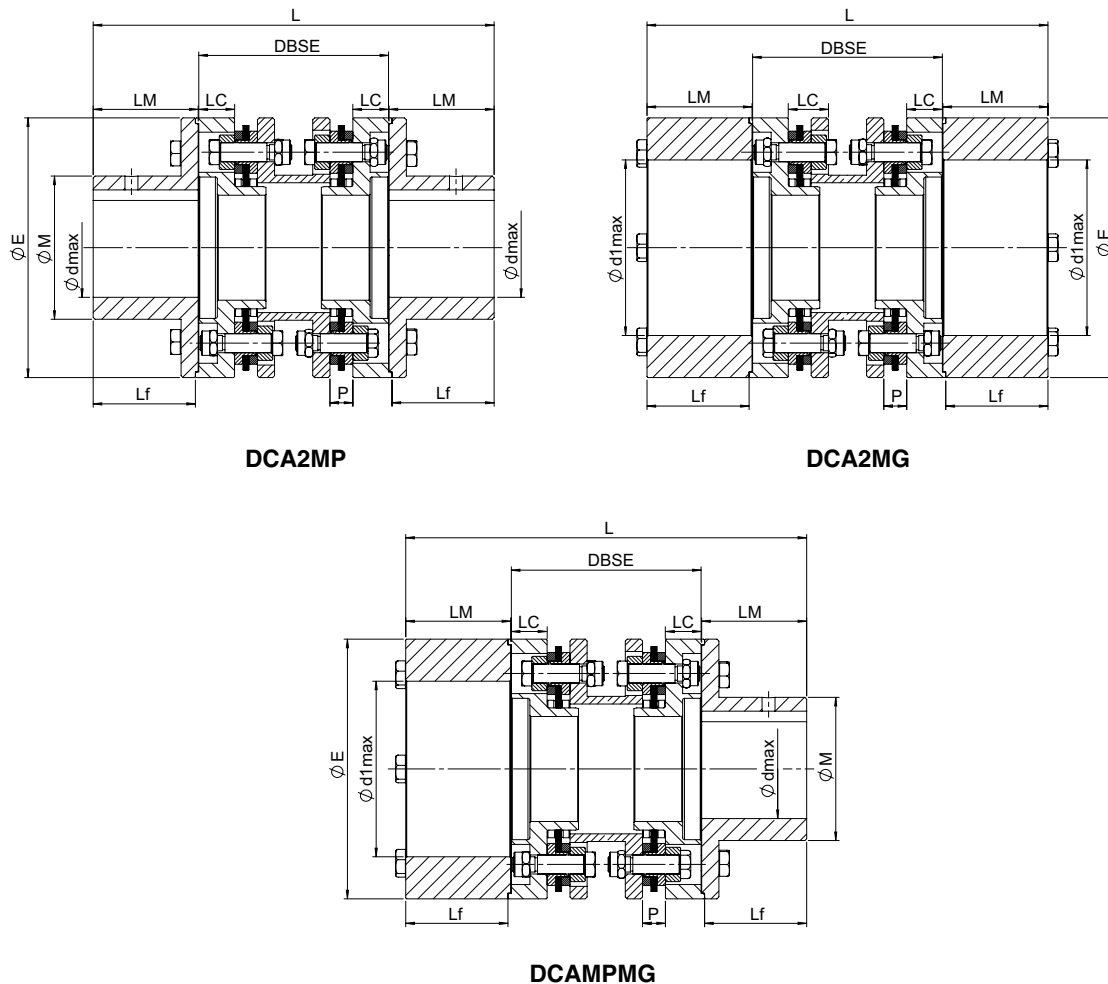

METALDRIVE®

Size	Dimensions [mm]													
	d max.	d1 max.	E	M	Lf	LC	P	LM	DBSE				L	
									min.	100	140	180		250
32	35	48	80	50	38,5	17,5	8	40	80	X	X			DBSE + 80
38	42	55	92	60	43,5	20	8	45	90	X	X			DBSE + 90
45	52	75	112	74	43,5	19	10	45	90	X	X			DBSE + 90
52	65	92	136	90	53,5	19	12	55	100	X	X	X		DBSE + 110
65	80	105	162	112	63,5	23,5	13	65	120		X	X	X	DBSE + 130
80	95	120	182	132	78	27	14	80	140		X	X	X	DBSE + 160
90	105	135	206	145	78	26,5	15	80	140		X	X	X	DBSE + 160
95	118	-	226	165	88	28,5	22	90	160			X	X	DBSE + 180
110	125	-	252	175	98	33	25	100	180			X	X	DBSE + 200
120	140	-	296	198	108	42,5	32	110	220					DBSE + 220
138	155	-	318	217	137	51,5	32	140	260					DBSE + 280
155	180	-	352	245	147	58,5	32	150	280					DBSE + 300
175	190	-	386	270	172	59,5	37	175	310					DBSE + 350
190	205	-	426	290	186	68,5	37	190	340					DBSE + 380
205	230	-	456	325	201	75	42	205	370					DBSE + 410

These DBSE sizes are more readily available. Other lengths to suit specific shaft separations are available on request.

METALDRIVE® GMD type “SA1” - “SA2”

Metaldrive coupling with intermediate shaft is available in two versions:

SA1: Tubular Shaft version. Shaft is available in various lengths and can be delivered in welded aluminum, steel or **carbon**.

SA2: Solid shaft construction. Shaft is available in various lengths.

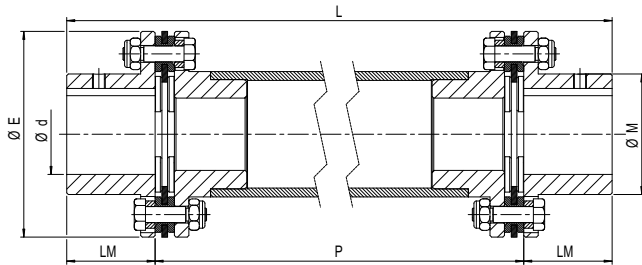

SA1

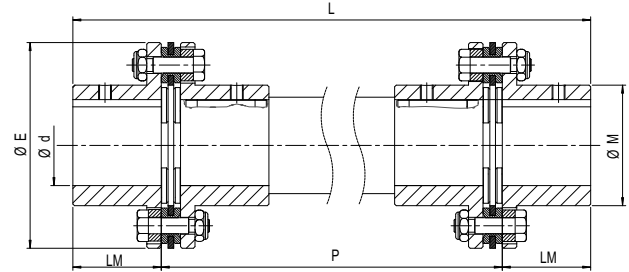

SA2

Size	Dimensions [mm]					
	d max	E	M	LM	P	L
32	32	80	45	40	Shaft lengths on request	P+ 80
38	38	92	53	45		P+ 90
45	45	112	64	45		P+ 90
52	52	136	75	55		P+ 110
65	65	162	92	65		P+ 130
80	80	182	112	80		P+ 160
90	90	206	130	80		P+ 160
95	95	226	135	90		P+ 180
110	110	252	155	100		P+ 200
120	120	296	170	110		P+ 220
138	138	318	195	140		P+ 280
155	155	352	218	150		P+ 300
175	175	386	252	175		P+350
190	190	426	272	190		P+ 380
205	205	456	292	205	P+ 410	

Coupling configurator

Coupling code	Item	Type	Execution	Bore diameter	Order example
GMDL032	Hub 1	GMD	S	F...	GMD032MF30
	(SA1 o SA2) type and distance between two side shaft Length P				SA1 P = 1200 mm
	Hub 2	GMD	S	F...	GMD032MF25

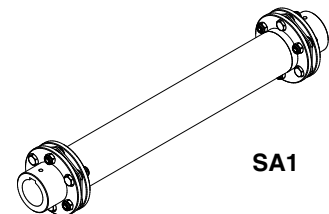

SA1

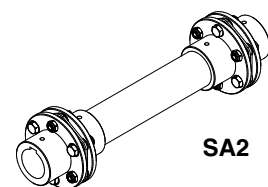

SA2

Hub-shaft connections

keyway hub

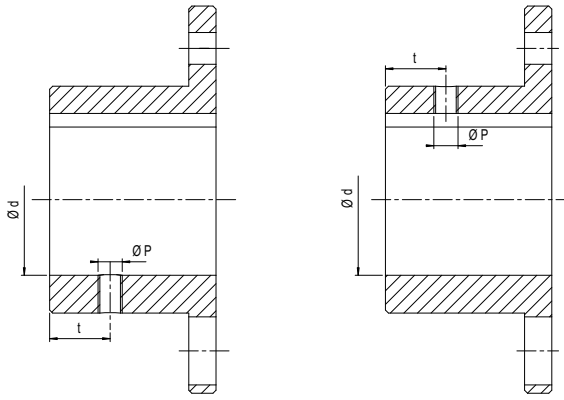

up to size 52

from size 65

Size	Prebored [mm]	d max [mm]	P	t [mm]	Setscrew tightening torque Ms [Nm]
32	-	32	M6	15	4,8
38	-	38	M6	15	4,8
45	-	45	M8	20	10
52	-	52	M8	20	10
65	-	65	M8	20	10
80	35	80	M10	20	17
90	50	90	M12	25	40
95	55	95	M12	30	40
110	65	110	M12	30	40
120	75	120	M12	30	40
138	80	138	a richiesta		
155	80	155			
175	80	175			
190	80	190			
205	80	205			

Shrink disc executions

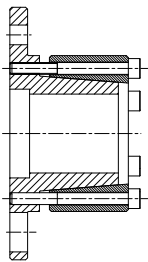

Shrink disc hub E

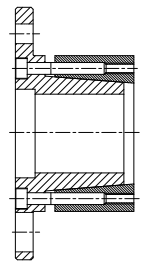

Shrink disc hub I

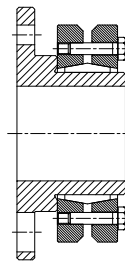

With SIT-LOCK® 11S

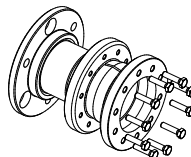
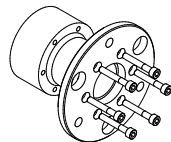
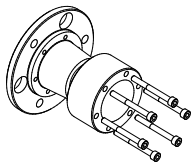

Split collar design

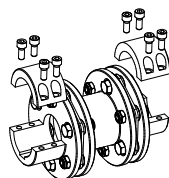
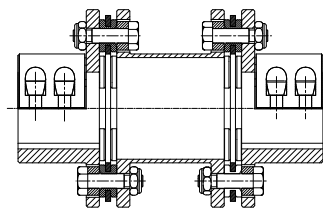
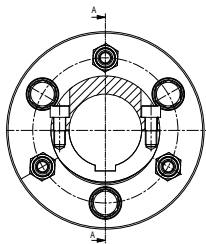

Selection procedure

Definitions

T_{Kmax} = peak torque capacity for a maximum of 10^5 times [Nm]

T_{Kn} = torque transmissible by the coupling at the maximum RPM with the allowable misalignments [Nm]

T_{KW} = maximum torque variation allowable by the coupling from the nominal torque T_{KN} with a frequency of 10 Hz [Nm]

Coupling selection

- Calculate the nominal torque to be transmitted:

$$T_N = \frac{9550 \cdot P}{n}$$

T_N = nominal torque of the machine [Nm]

P = input power (kW)

n = RPM (1/min)

- Verify coupling nominal torque T_{Kn} :

$$T_{Kn} \geq T_N \cdot k$$

k = service factor

- Verify coupling maximum torque with machine peak and starting torque. It is allowed up to 5 peaks or start up per hour:

$$T_{Kmax} \geq T_S$$

T_S = starting or peak torque [Nm]

- In case of direct start with AC motor, it is important to consider driver and driven inertias. In case of transmission with torque inversion, the maximum torque variation T_w should not be higher than the maximum coupling torque T_{kw} .

$$T_{kw} \geq T_w$$

- Verify working conditions.

Particularly maximum speed must not exceed the permissible value. Dynamic balancing (optional) allows higher speeds. Permissible speed could be limited by the weight and critical speed of spacers. Please consult with our technical department.

Service factor k and load classification

Compressors	
Piston compressors	H
Turbo compressors	M
Blowers, Ventilators	
Rotary piston blowers	M
Blowers (axial / radial)	U
Cooling tower fans	M
Turbo blowers	U
Pumps	
Centrifugal pumps (low viscosity liquid)	U
Centrifugal pumps (viscous liquid)	M
Piston pumps	H
Plunger pumps	H
Pressure pumps	H
Food industry machinery	
Bottling and container filling	U
Cane crushers, knives, mills	M
Bread machines	U
Packaging machines	U
Sugar beet machines	M
Chemical industry	
Agitators (liquid material)	U
Agitators (semi-liquid material)	M
Centrifuges (heavy)	M

Centrifuges (light)	U
Drums	M
Mixers	M
Building machinery	
Concrete mixers	M
Hoists	M
Road construction machinery	M
Generators, transformers	
Frequency transformers	H
Generators	M
Welding generators	M
Cranes	
Hoisting	U
Slewing	M
Travelling	H
Laundry machines	
Tumblers	M
Washing machines	M
Wood working machines	
Barkers	H
Planing machines	M
Saw frames	H
Wood working machines	U

Marble, clay, and stone working machines	
Mills	H
Breakers	H
Brick presses	H
Ovens (rotary)	H
Metal rolling mills	
Cold rolling mills	H
Casting plants (continuous)	H
Heavy and medium plate mills	H
Manipulators	H
Roller tables (heavy)	H
Roller tables (light)	M
Sheet mills	H
Forging presses	H
Hammers	H
Machine tools, auxiliary drive	U
Machine tools, main drives	M
Metal planning machines	H
Plate straightening machine	H
Presses	H
Sheet metal bending machines	M

Driver machine	Driver machine load class		
	U	M	H
Electric motor, turbine, hydraulic motor	1,1	1,5	2
Piston engines with more than 3 cylinders	1,5	1,7	2,3
Piston engines up to 3 cylinders	1,7	2	2,6

U = uniform load
M = medium frequency peak load
H = high frequency peak load

METALDRIVE® couplings weight and inertia

Size	Component										Complete coupling													
	Hub with max bore				Spacer GMD type DC				Disc pack		GMD type S hub with max bore		GMD type DCL hub with max bore		GMD type DCC hub with max bore		GMD type DC1MR hub with max		GMD type 2MR hub with max bore		GMD type DCC1MR hub with max			
	Hub M		Hub M1		Type P1		Type P2				Weight kg	Moment of inertia kg · m ²	Weight kg	Moment of inertia kg · m ²	Weight kg	Moment of inertia kg · m ²	Weight kg	Moment of inertia kg · m ²	Weight kg	Moment of inertia kg · m ²	Weight kg	Moment of inertia kg · m ²	Weight kg	Moment of inertia kg · m ²
	Weight kg	Moment of inertia kg · m ²	Weight kg	Moment of inertia kg · m ²	Weight kg	Moment of inertia kg · m ²	Weight kg	Moment of inertia kg · m ²	Weight kg	Moment of inertia kg · m ²														
32	0,38	0,000253	0,32	0,00021	0,52	0,00042	0,42	0,00038	0,078	0,000034	0,8	0,0005	1,4	0,001	1,3	0,001	1,3	0,001	1,2	0,001	1,2	0,001	1,2	0,001
38	0,57	0,00049	0,5	0,0004	0,71	0,00081	0,58	0,0007	0,094	0,000109	1,2	0,0011	2	0,002	1,9	0,0019	1,9	0,0019	1,8	0,0018	1,8	0,0018	1,8	0,0018
45	0,86	0,0011	0,76	0,00092	0,97	0,0016	0,82	0,0015	0,183	0,00031	1,9	0,0025	3,1	0,0044	3	0,0043	3	0,0042	2,9	0,004	2,9	0,0041	2,9	0,0041
52	1,57	0,0029	1,22	0,0024	1,7	0,0044	1,5	0,0041	0,31	0,00076	3,5	0,0066	5,5	0,0117	5,3	0,0114	5,2	0,0112	4,9	0,0107	5	0,0109	5	0,0109
65	2,5	0,0064	2,1	0,0055	2,4	0,009	2,1	0,0082	0,45	0,0015	5,5	0,0143	8,3	0,0248	8	0,024	7,9	0,0239	7,5	0,023	7,6	0,0231	7,6	0,0231
80	4,3	0,0147	3,87	0,0126	4	0,02	3,4	0,018	0,56	0,0024	9,2	0,0318	13,7	0,0542	13,1	0,0522	13,3	0,0521	12,9	0,05	12,7	0,0501	12,7	0,0501
90	5,9	0,026	5,1	0,021	5,4	0,033	4,4	0,03	0,75	0,0042	12,6	0,0562	18,7	0,0934	17,7	0,0904	17,9	0,0884	17,1	0,0834	16,9	0,0854	16,9	0,0854
95	7,2	0,037	6,4	0,032	6,8	0,05	5,8	0,045	1,7	0,012	16,1	0,086	24,6	0,148	23,6	0,143	23,8	0,143	23	0,138	22,8	0,138	22,8	0,138
110	10,3	0,068	9,2	0,057	10	0,09	8,3	0,08	2,4	0,022	23	0,158	35,4	0,27	33,7	0,26	34,3	0,259	33,2	0,248	32,6	0,249	32,6	0,249
120	14,4	0,125	13,1	0,11	13,7	0,17	11,8	0,16	4,9	0,058	33,7	0,308	52,3	0,536	50,4	0,526	51	0,521	49,7	0,506	49,1	0,511	49,1	0,511
138	22,6	0,232	18,9	0,19	21,3	0,3	17,4	0,27	5,4	0,078	50,6	0,542	77,3	0,92	73,4	0,89	73,6	0,878	69,9	0,836	69,7	0,848	69,7	0,848
155	29,86	0,38	24,73	0,3	32,1	0,54	25	0,46	6,1	0,113	65,8	0,873	104	1,526	96,9	1,446	98,9	1,446	93,8	1,366	91,8	1,366	91,8	1,366
175	46,3	0,73	37,7	0,55	46,9	0,97	35,7	0,81	9,3	0,215	101,9	1,675	158,1	2,86	146,9	2,7	149,5	2,68	140,9	2,5	138,3	2,52	138,3	2,52
190	59,9	1,14	47,7	0,88	59,9	1,53	47	1,32	11	0,3	130,8	2,658	201,7	4,41	188,8	4,2	189,5	4,15	177,3	3,89	176,6	3,94	176,6	3,94
205	74	1,63	57	1,21	85	2,36	64	1,98	15,3	0,48	163,3	3,74	263,6	6,58	242,6	6,2	246,6	6,16	229,6	5,74	225,6	5,78	225,6	5,78

Note
Values for hubs refer to maximum bore execution. Values for disc packs include bolts.

Disc pack executions

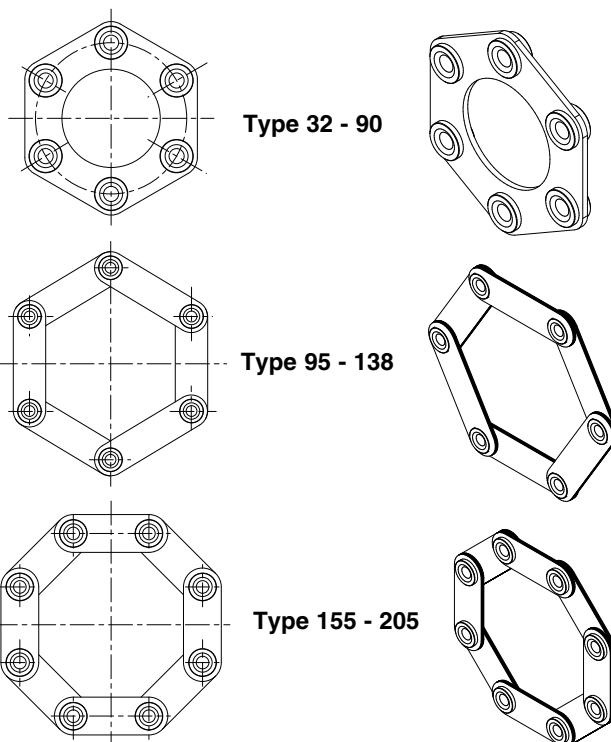

Installation and maintenance

METALDRIVE® couplings come standard unassembled (unless ordered to be assembled).

When mounting the coupling, it is important to follow the specific recommendations.

Due to the modular design of the METALDRIVE® coupling, single parts can be replaced. For optimum performance all components must be in perfect conditions.

METALDRIVE® couplings are designed for horizontal mounting. In case of vertical mounting, the coupling weight must be supported.

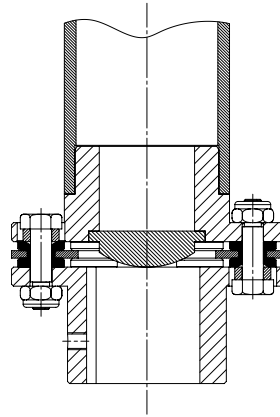

Metaldrive® with vertical assembling

- Carefully clean bores, shaft ends and the flange where the screws are positioned
- Position the hubs on the shafts of the machines. Hub faces must be flush with shaft end. Introduce setscrew and tighten properly
- Position the driver and driven unit to be connected
- Carefully align the shafts to be connected. Proper initial alignment allows misalignments during motion and ensures transmission durability. It is therefore suggested to check shaft alignments with an indicator before the machine start up.
- Mount the disc pack with screws and nuts. Tighten to torque M_s holding the screws and turning the nuts.
- Install the spacer between the hubs and connect it to the already assembled disc pack with screws and nuts (in case of long spacer, it is important to support the spacer). Tighten to torque M_s holding the screws still and turning the nuts
- Check shaft alignment again.

In case hubs are machined by the user, it is recommended to ask for correct concentricity and perpendicularity tolerances which could affect coupling life.

There is no need for lubrication.

Safety norms

All rotating parts must be protected against any possibility of contact with people.

Protection must be designed so that even in case of coupling failure, personnel and equipment is protected.