

SERVOMATE® Disc couplings



SERVOMATE®

Contents

SERVOMATE® Disc Couplings	Page
Description	69
Standard execution	69



SERVOMATE® disc couplings

SERVOMATE® disc couplings have been specially designed for servomotor applications. The aluminium hubs and the compact design provide low mass

moment of inertia resulting in a reliable and maintenance free coupling for high speeds. The double disk pack execution has been designed for applications with radial misalignment.

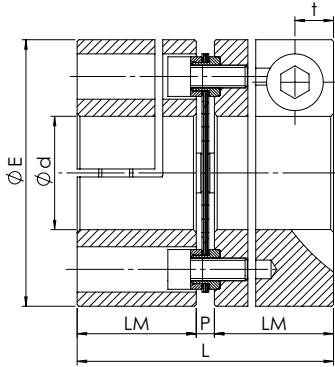

GSM

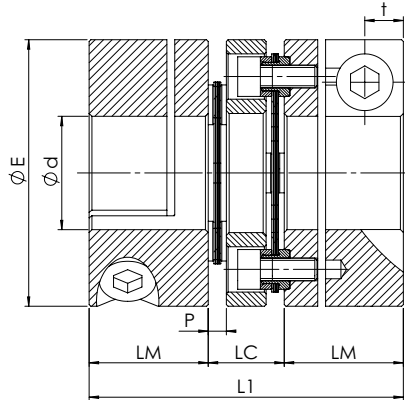

GSMC



SERVOMATE®

Size	Dimensions [mm]								Screw		Weights and moments of inertia				TKN [Nm]	TKmax [Nm]	Torsional rigidity CT [Nm/rad]		Max. speed [rpm]
	dmax	E	LC	LM	L	L1	P	t	Type	Ms [Nm]	GSM		GSMC				GSM	GSMC	
											W* [Kg]	J* [Kg · m²]	W* [Kg]	J* [Kg · m²]					
15	20	47	13	21	45	55	3	6,8	M6	10	0,16	52 · 10 ⁻⁶	0,20	63 · 10 ⁻⁶	20	40	12.000	6.000	16.000
20	25	59	19	24	52	67	4	6,5	M6	10	0,30	149 · 10 ⁻⁶	0,40	194 · 10 ⁻⁶	30	60	30.000	15.000	12.000
25	35	70	24	32	69	88	5	9,0	M8	25	0,53	384 · 10 ⁻⁶	0,66	492 · 10 ⁻⁶	60	120	60.000	30.000	10.000

*= with max bore

Size	Misalignment GSM			Misalignment GSMC		
	Radial [mm]	Axial [mm]	Angular [°]	Radial [mm]	Axial [mm]	Angular [°]
15	-	0,5	1	0,16	1,0	1
20	-	0,6	1	0,25	1,2	1
25	-	0,8	1	0,30	1,6	1

Size	Trasmissible torque [Nm] related to shaft diameter [mm]														
	Ø10	Ø11	Ø12	Ø14	Ø15	Ø16	Ø19	Ø20	Ø22	Ø24	Ø25	Ø28	Ø30	Ø32	Ø35
15	20	22	24	28	30	32	38	40	-	-	-	-	-	-	-
20	-	-	24	28	30	32	38	40	44	48	50	-	-	-	-
25	-	-	-	-	55	59	70	73	81	88	92	103	110	117	128

Order form

Coupling

1 disc pack execution: GSM
 2 disc packs + spacer execution: GSMC

Size

